

650V GaN Power Transistor (FET)

Features

- Easy to use, compatible with standard gate drivers
- Excellent $Q_G \times R_{DS(on)}$ figure of merit (FOM)
- Low Q_{RR} , no free-wheeling diode required
- Low switching loss
- RoHS compliant and Halogen-free

Product Summary		
V_{DSS}	650	V
$R_{DS(on), typ}$	720	m Ω
$Q_{G, typ}$	15	nC
$Q_{RR, typ}$	20	nC

Applications

- High efficiency power supplies
- High efficiency USB PD adapters
- Other consumer electronics

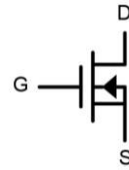
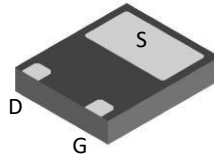

Schematic Symbol

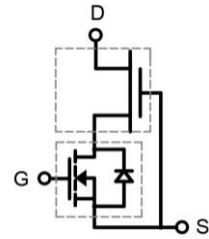

Cascode Device Structure

Packaging

Part Number	Package	Packaging	Base QTY
RX65T720MS2A	DFN 5 x 6	Tape and Reel	5000

Maximum ratings, at $T_c=25^\circ\text{C}$, unless otherwise specified

Symbol	Parameter	Limit Value	Unit
I_D	Continuous drain current @ $T_c=25^\circ\text{C}$	2.7	A
	Continuous drain current @ $T_c=100^\circ\text{C}$	1.7	A
I_{DM}	Pulsed drain current @ $T_c=25^\circ\text{C}$ (pulse width: 10us)	12.8	A
	Pulsed drain current @ $T_c=150^\circ\text{C}$ (pulse width: 10us)	7.4	A
V_{DSS}	Drain to source voltage ($T_J = -55^\circ\text{C}$ to 150°C)	650	V
V_{TDSS}	Transient drain to source voltage ^a	800	V
V_{GSS}	Gate to source voltage	± 20	V
P_D	Maximum power dissipation @ $T_c=25^\circ\text{C}$	11	W
T_C	Operating temperature	-55 to 150	$^\circ\text{C}$
T_J		-55 to 150	$^\circ\text{C}$
T_S	Storage temperature	-55 to 150	$^\circ\text{C}$
T_{CSOLD}	Soldering peak temperature	260	$^\circ\text{C}$

Thermal Resistance

Symbol	Parameter	Typical	Unit
R _{θJC}	Junction-to-case	11.4	°C/W
R _{θJA}	Junction-to-ambient ^b	50	°C/W

Notes:

- a. Off-state spike duty cycle < 0.01, spike duration < 2us
- b. Device on one layer epoxy PCB for drain connection (vertical and without air stream cooling, with 6cm² copper area and 70μm thickness)

Electrical Parameters, at $T_J=25\text{ }^\circ\text{C}$, unless otherwise specified

Symbol	Min	Typ	Max	Unit	Test Conditions
Forward Characteristics					
$V_{DSS-MAX}$	650	-	-	V	$V_{GS}=0V$
BV_{DSS}	-	1000	-	V	$V_{GS}=0V, I_{DSS}=250\mu A$
$V_{GS(th)}$	1.1	1.8	2.5	V	$V_{DS}=V_{GS}, I_D=500\mu A$
$R_{DS(on)}^c$		720	900	m Ω	$V_{GS}=8V, I_D=4A, T_J=25^\circ C$
	-	1440	-		$V_{GS}=8V, I_D=4A, T_J=150^\circ C$
I_{DSS}	-	8	20	μA	$V_{DS}=700V, V_{GS}=0V, T_J=25^\circ C$
	-	50	-	μA	$V_{DS}=700V, V_{GS}=0V, T_J=150^\circ C$
I_{GSS}	-	-	150	nA	$V_{GS}=20V$
	-	-	-150	nA	$V_{GS}=-20V$
C_{ISS}	-	300	-	pF	$V_{GS}=0V, V_{DS}=650V, f=1MHz$
C_{OSS}	-	9	-	pF	
C_{RSS}	-	1	-	pF	
$C_{O(er)}$	-	13	-	pF	$V_{GS}=0V, V_{DS}=0 - 650V$
$C_{O(tr)}$	-	35	-	pF	
Q_G	-	15	-	nC	$V_{DS}=400V, V_{GS}=0 - 12V, I_D=5.5A$
Q_{GS}	-	2.5	-		
Q_{GD}	-	3	-		
$t_{D(on)}$	-	10	-	ns	$V_{DS}=400V, V_{GS}=0 - 12V, I_D=3A, R_G=30\Omega$
t_R	-	6	-		
$t_{D(off)}$	-	40	-		
t_F	-	10	-		
Reverse Characteristics					
V_{SD}	-	1.2	-	V	$V_{GS}=0V, I_S=2A, T_J=25^\circ C$
	-	1.7	-		$V_{GS}=0V, I_S=5A, T_J=25^\circ C$
	-	2	-		$V_{GS}=0V, I_S=5A, T_J=150^\circ C$
t_{RR}	-	12	-	ns	$I_S=3A, V_{GS}=0V, d_i/d_t=1000A/us, V_{DD}=400V$
Q_{RR}	-	20	-		

Notes:

c. Dynamic on-resistance; see Figure 17 and 18 for test circuit and configurations

Circuit Implementation

Mostly used in flyback, forward and push-pull converters

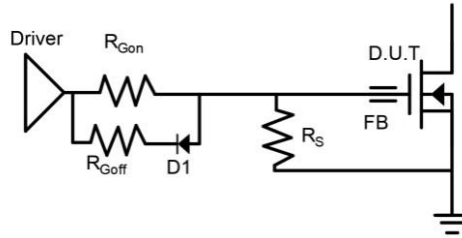
Recommended Single Ended Drive Circuit

Recommended gate drive: (0 V, 12 V) with $R_{Gon} = 300 - 500 \Omega$, $R_{Goff} = 10 \Omega$

Gate Ferrite Bead (FB)	Gate Resistance (R_{Gon})	Gate Resistance (R_{Goff})	Gate Source Resistance (R_S)	Gate Diode (D1)
300 - 600 Ω @100 MHz	300 - 500 Ω	10 Ω	10 k Ω	1N4148

Typical Characteristics, at $T_c=25^\circ\text{C}$, unless otherwise specified

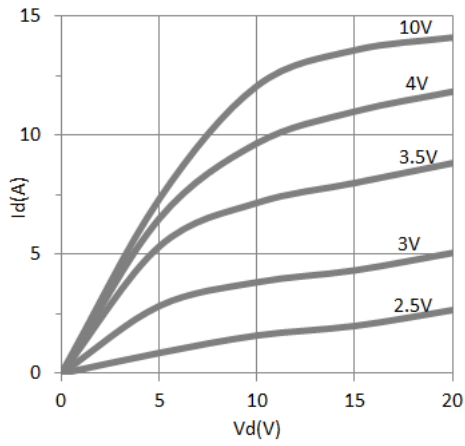

Figure 1. Typical Output Characteristics $T_j=25^\circ\text{C}$

Parameter: V_{GS}

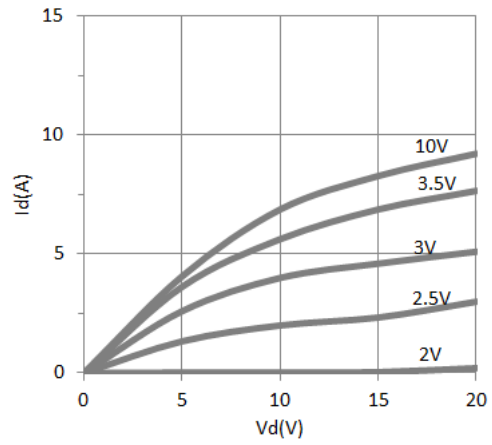

Figure 2. Typical Output Characteristics $T_j=150^\circ\text{C}$

Parameter: V_{GS}

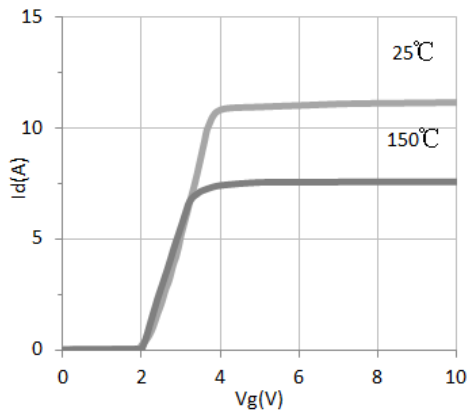

Figure 3. Typical Transfer Characteristics

$V_{DS}=10\text{V}$, Parameter: T_j

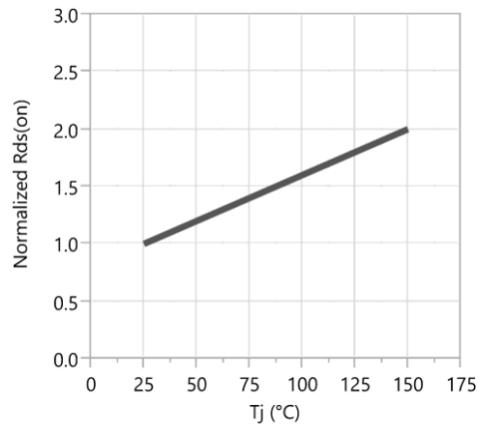

Figure 4. Normalized On-resistance

$I_D=4\text{A}$, $V_{GS}=8\text{V}$

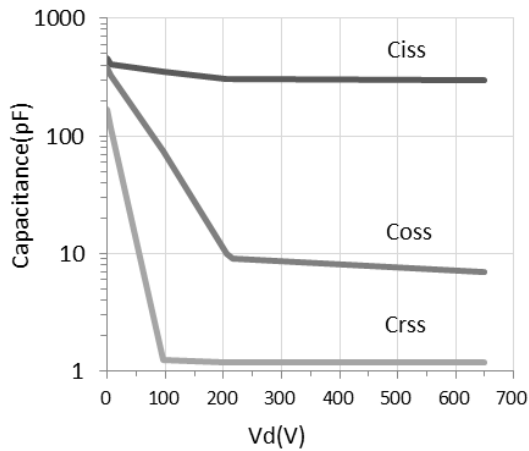

Figure 5. Typical Capacitance

$V_{GS}=0\text{V}$, $f=1\text{MHz}$

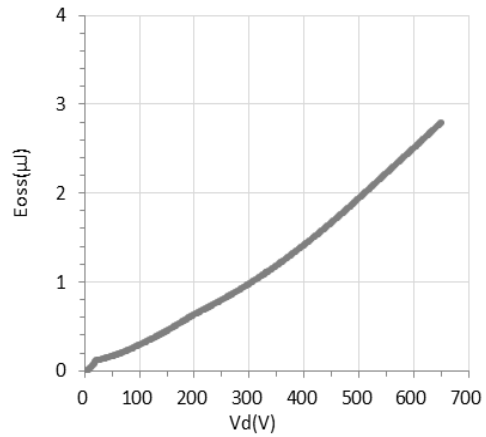

Figure 6. Typical C_{oss} Stored Energy

Typical Characteristics, at $T_c=25^\circ\text{C}$, unless otherwise specified

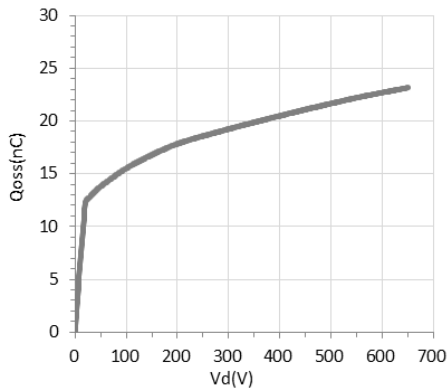

Figure 7. Typical Qoss

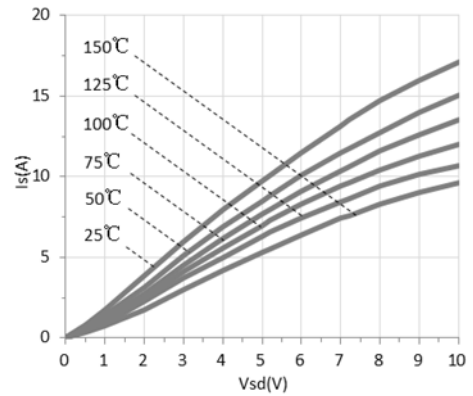

Figure 8. Forward Characteristic of Rev. Diode

$I_s=f(V_{sd}), \text{Parameter } T_j$

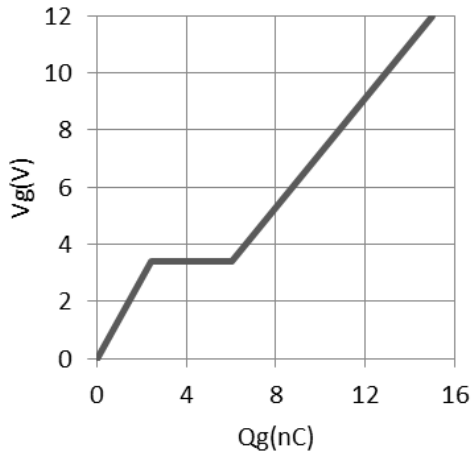

Figure 9. Typical Gate Charge

$I_{DS}=5.5\text{A}, V_{DS}=400\text{V}$

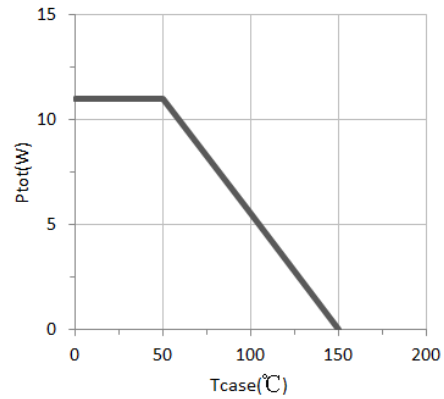

Figure 10. Power Dissipation

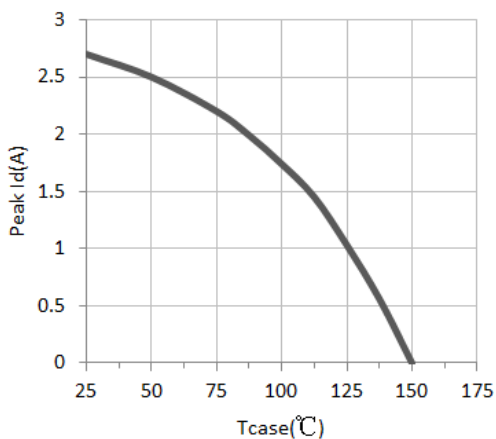

Figure 11. Current Derating

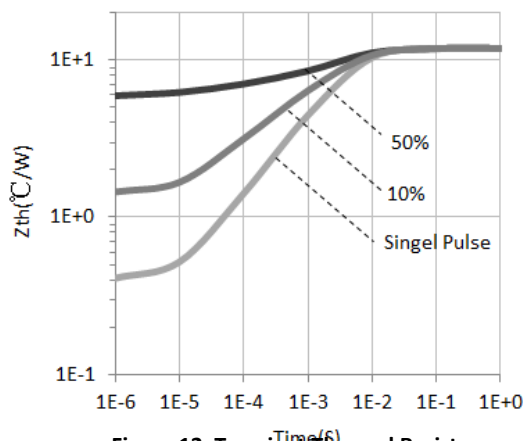

Figure 12. Transient Thermal Resistance

Typical Characteristics, at $T_c=25\text{ }^\circ\text{C}$, unless otherwise specified

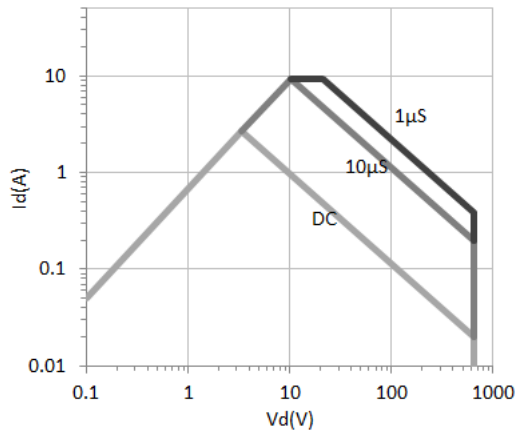

Figure 13. Safe Operating Area $T_c=25\text{ }^\circ\text{C}$

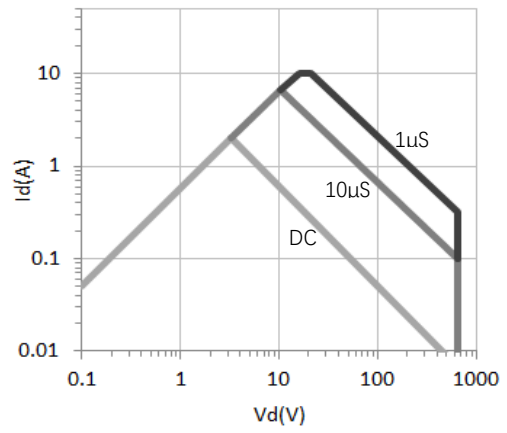

Figure 14. Safe Operating Area $T_c=80\text{ }^\circ\text{C}$

Test Circuits and Waveforms

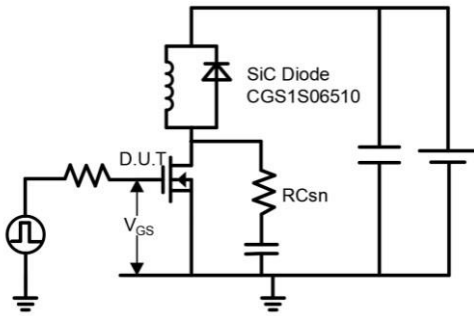

Figure 15. Switching Time Test Circuit

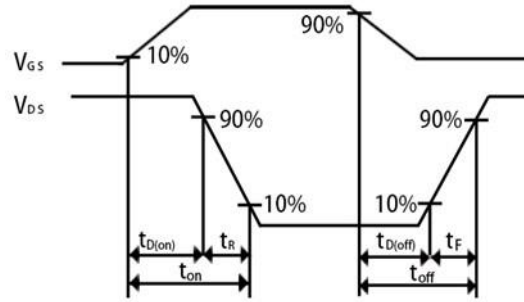

Figure 16. Switching Time Waveform

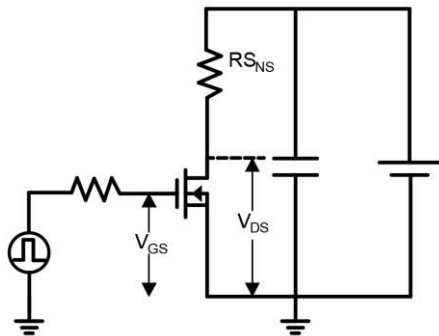

Figure 17. Dynamic $R_{DS(on)}$ Test Circuit

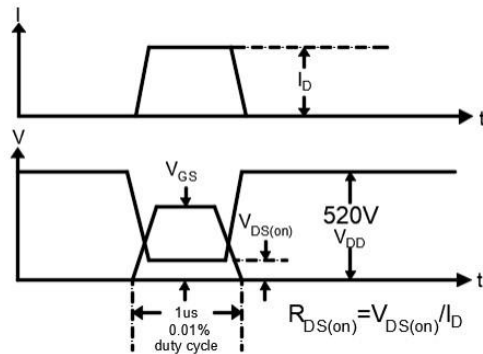

Figure 18. Dynamic $R_{DS(on)}$ Waveform

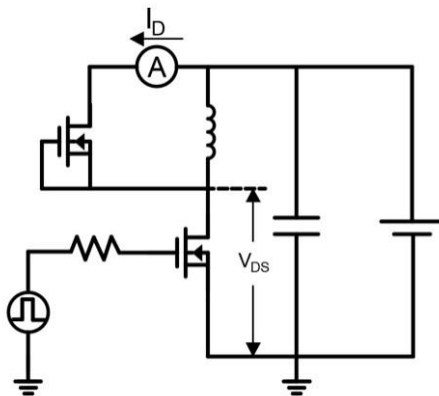

Figure 19. Diode Characteristic Test Circuits

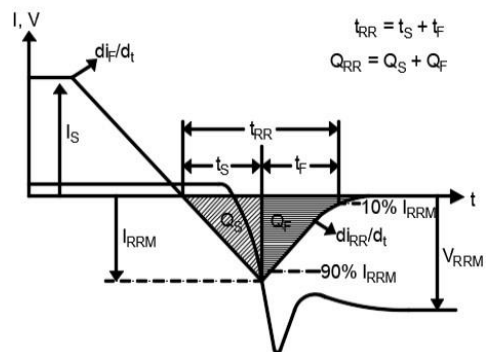

Figure 20. Diode Recovery Waveform

Design Considerations

Fast switching GaN device can reduce power conversion losses, and thus enable high frequency operations. Certain PCB design rules and instructions, however, need to be followed to take full advantages of fast switching GaN devices.

Before evaluating Runxin Micro's GaN devices, please refer to the table below which provides some practical rules that should be followed during the evaluation.

When Evaluating Runxin Micro's GaN Devices:

DO	DO NOT
Make sure the traces are as short as possible for both drive and power loops to minimize parasitic inductance	Using Runxin Micro's devices in GDS board layouts
Use the test tool with the shortest inductive loop, and make sure test points should be placed close enough	Use differential mode probe or probe ground clip with long wires
Minimize the lead length of DFN 8*8mm packages when installing them to PCB	Use long traces in drive circuit, or long lead length of the devices

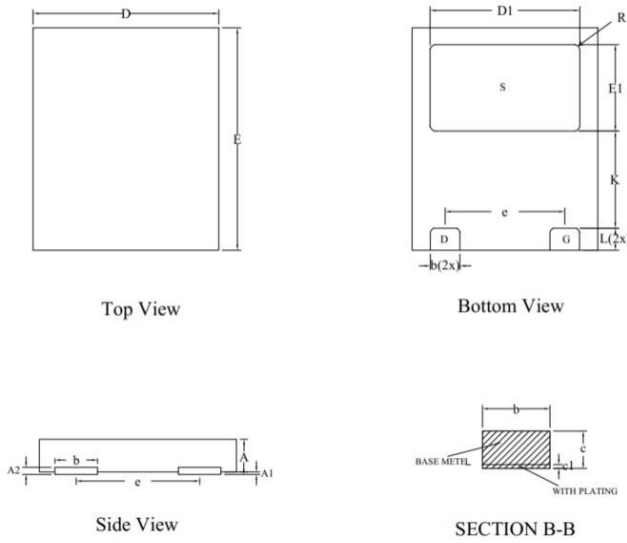
Package Outline
DFN 5 x 6mm (MS) Package

Symbol	Millimeter		
	Min	Nom	Max
A	0.85	1.00	1.15
A1	0.00	-	0.05
A2	-	0.20	0.22
b	0.82	0.87	0.92
c	-	0.20	-
c1	0.01	-	0.02
D	4.90	5.00	5.10
D1	4.09	4.24	4.39
E	5.90	6.00	6.10
E1	2.15	2.30	2.45
e	3.37BSC		
K	2.50	-	-
L	0.71	0.81	0.91
R	-	0.13	-

Tape and Reel Information

Dimensions are shown in millimeters

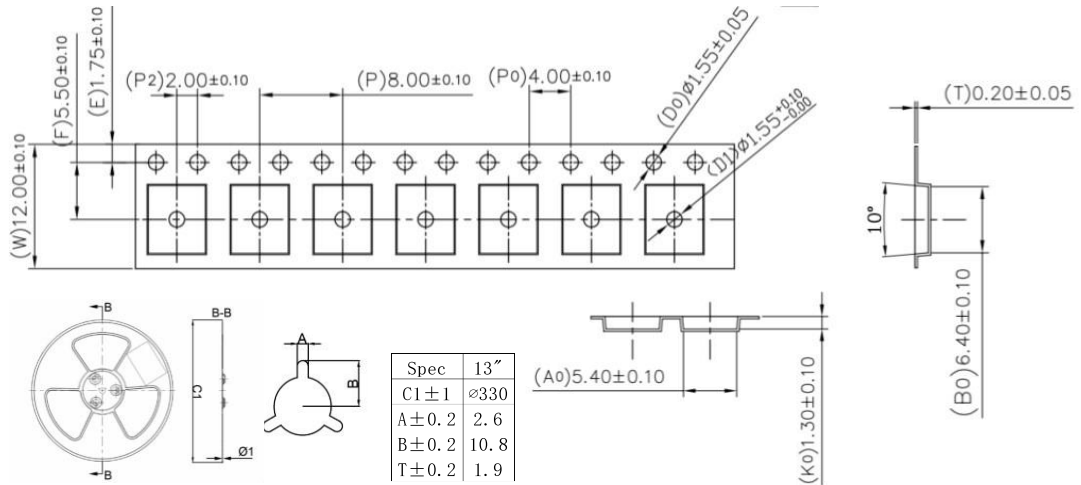

Recommended PCB Layout & Metal mask opening

Dimensions are shown in millimeters

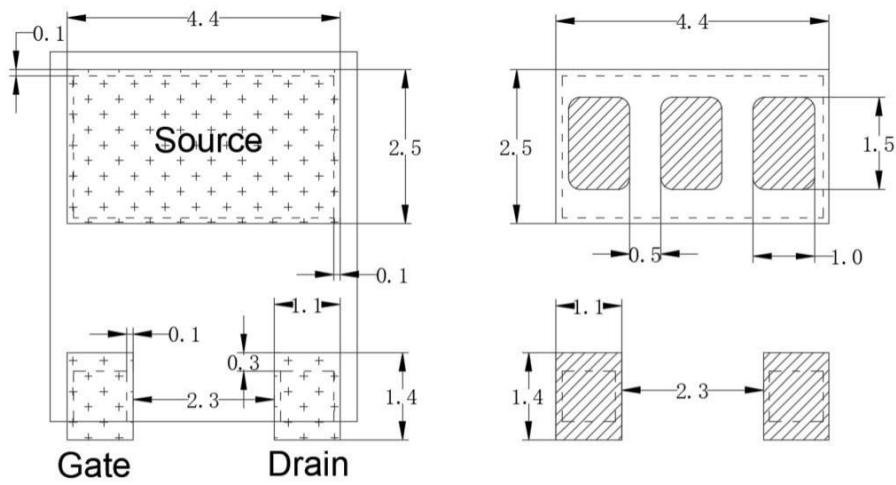
Revision History

Version	Date	Change(s)
0.1	03/07/2023	Released preliminary datasheet